

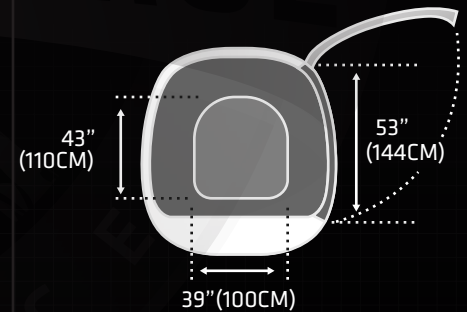

EMBRAER EMB-110 BANDIT

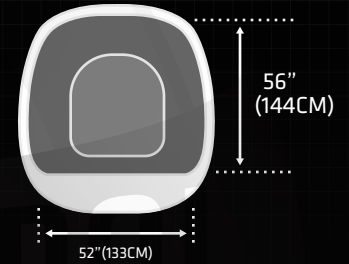
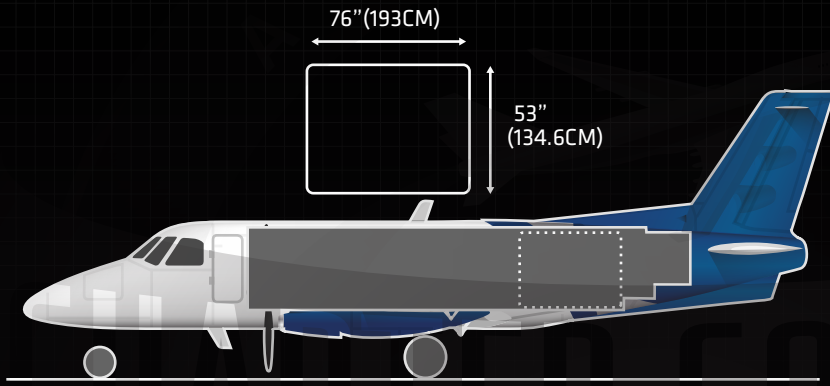

SPECIFICATIONS

IMPERIAL

METRIC

MANUFACTURER	EMBRAER	
TYPE	EMB - 110 BANDIT	
CRUISE SPEED	250 MPH	402 KPH
MAX. PAYLOAD	3,000 LB	1,361 KG
MAX. VOLUME	450 CBF	13 CBM
CARGO HOLD SIZE LXWXH	232" X 52" X 56"	589CM X 132CM X 142CM
MAIN SIDE/NOSE DOOR SIZE WXH	76" X 53"	193CM X 135CM
RANGE FULLY LOADED	1,220 MI	1,964 KM
FUEL CAPACITY	441 GAL	1,670 L
LOWER FORWARD DOOR WXH	N/A	N/A
LOWER AFT DOOR WXH	N/A	N/A