

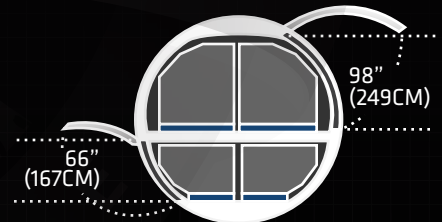

MCDONNELL DOUGLAS MD-11F

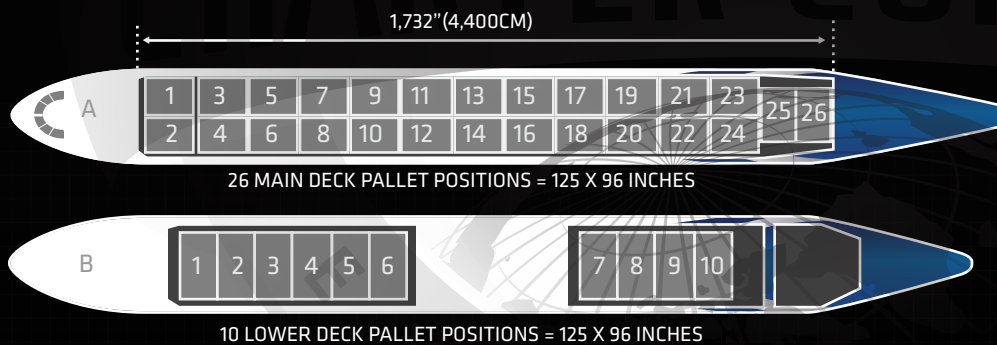
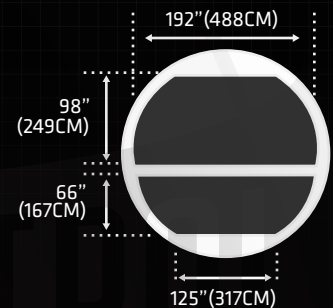
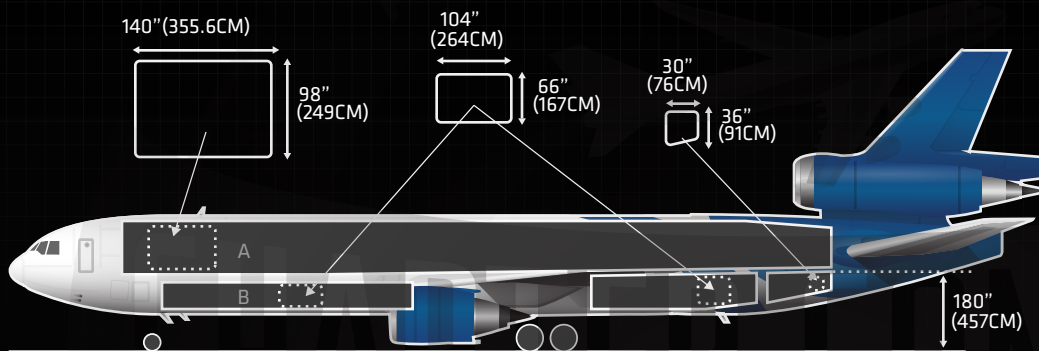

SPECIFICATIONS

IMPERIAL

METRIC

MANUFACTURER	MCDONNELL DOUGLAS	
TYPE	MD-11F	
CRUISE SPEED	540 MPH	869 KPH
MAX. PAYLOAD	187,500 LB	85,049 KG
MAX. VOLUME	20,278 CBF	577 CBM
CARGO HOLD SIZE LXWXH	1,692" X 192" X 96"	4,298CM X 488CM X 244CM
MAIN SIDE/NOSE DOOR SIZE WXH	S: 140" X 98"	S: 356CN X 249CM
RANGE FULLY LOADED	3,950 NMI	7,320 KM
FUEL CAPACITY	38,615 US GAL	146,170 L
LOWER FORWARD DOOR WXH	104" X 66"	264CM X 168CM
LOWER AFT DOOR WXH	104" X 66"	264CM X 168CM